

# Technical data sheet

## Product features



### Vacuum packing machine 20 m3/h, 410 mm

<b>Model</b>	<b>SAP Code</b>	00013548
--------------	-----------------	----------



- Vacuum pump power [m3/h]: 20
- Length of sealing bar [mm]: 410
- Width of internal part [mm]: 435
- Depth of internal part [mm]: 455
- Height of internal part [mm]: 175
- Control type: Digital
- Gas flush: No
- Number of programs: 10
- Sealing time adjustment: Yes
- Vacuum time adjustment: Yes
- Lid security element: Yes
- Manometer: Yes

<b>SAP Code</b>	00013548	<b>Loading</b>	230 V / 1N - 50 Hz
<b>Net Width [mm]</b>	510	<b>Vacuum pump power [m3/h]</b>	20
<b>Net Depth [mm]</b>	570	<b>Length of sealing bar [mm]</b>	410
<b>Net Height [mm]</b>	525	<b>Width of internal part [mm]</b>	435
<b>Net Weight [kg]</b>	62.00	<b>Depth of internal part [mm]</b>	455
<b>Power electric [kW]</b>	0.750	<b>Height of internal part [mm]</b>	175

# Technical data sheet

Technical drawing



Vacuum packing machine 20 m<sup>3</sup>/h, 410 mm

Model

SAP Code

00013548

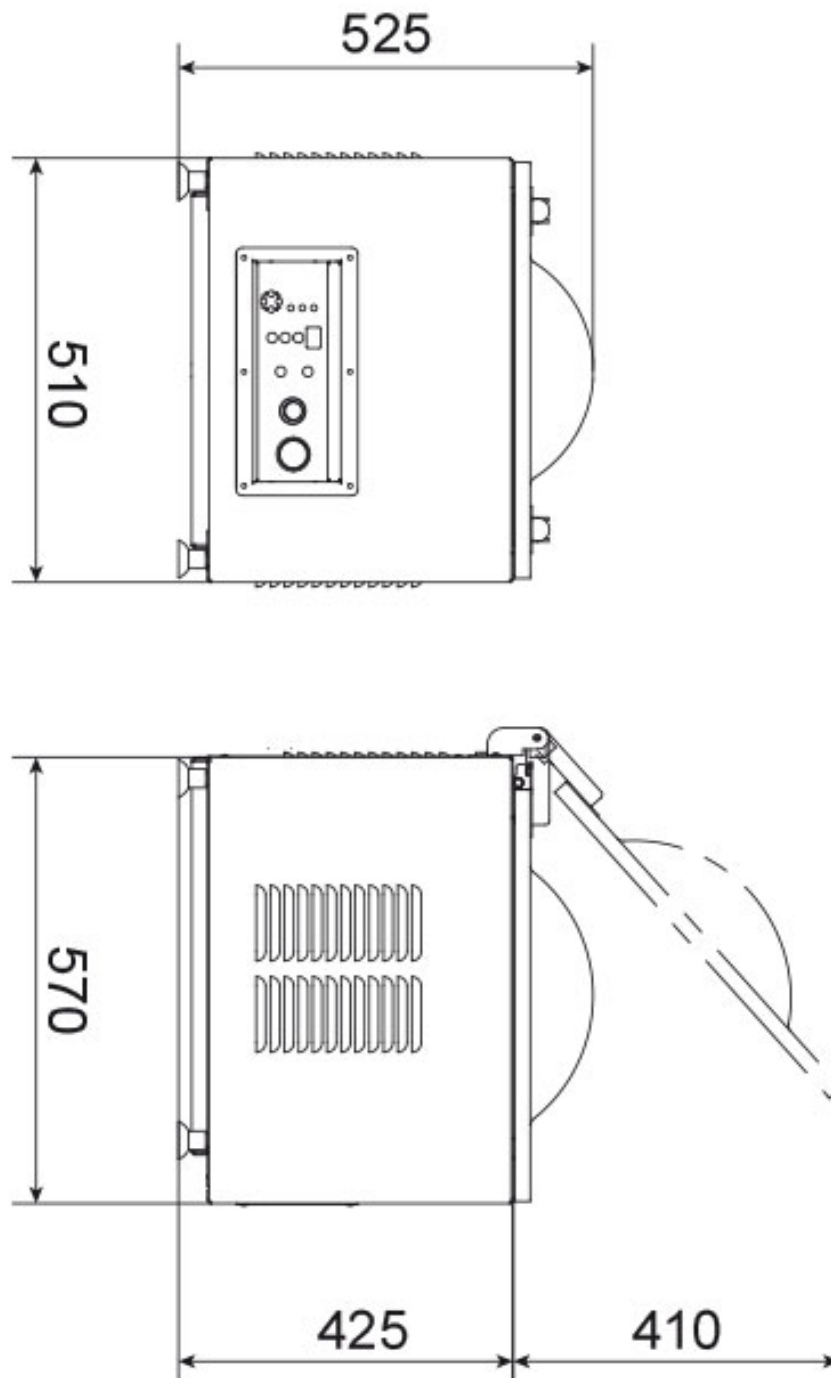

# Technical data sheet

## Product benefits



### Vacuum packing machine 20 m3/h, 410 mm

<b>Model</b>	<b>SAP Code</b>	00013548
--------------	-----------------	----------

1

#### Adjustable welding time

tighter packaging closure

- greater security of closure
- less error in operation

2

#### Convex plexiglass cover

greater variability of vacuuming

- possibility to vacuum larger quantities at once

3

#### Stainless steel chamber

endurance

easy maintenance

- easy to maintain thanks to the stainless steel chamber
- hygienic cleanliness

4

#### Softair slow return of air to the chamber

care for the product and the bag

- softair eliminates the risk of damage to the bag and the vacuumed food, thus saving costs

5

#### Rubber feet

vibration elimination

- nižší hlučnost zařízení
- prodloužení životnosti

# Technical data sheet

Technical parameters



Vacuum packing machine 20 m3/h, 410 mm

Model

SAP Code

00013548

**1. SAP Code:**

00013548

**2. Net Width [mm]:**

510

**3. Net Depth [mm]:**

570

**4. Net Height [mm]:**

525

**5. Net Weight [kg]:**

62.00

**6. Gross Width [mm]:**

700

**7. Gross depth [mm]:**

700

**8. Gross Height [mm]:**

620

**9. Gross Weight [kg]:**

86.00

**10. Device type:**

Electric unit

**11. Material:**

Stainless steel

**12. Power electric [kW]:**

0.750

**13. Loading:**

230 V / 1N - 50 Hz

**14. Control type:**

Digital

**15. Safety cover:**

transparent plexiglass

**16. Safety element:**

lid opening fuse

**17. Main switch:**

Yes

**18. Timer:**

Yes

**19. Gas flush:**

No

**20. Vacuum pump power [m3/h]:**

20

**21. Length of sealing bar [mm]:**

410

**22. Number of programs:**

10

**23. Sealing time adjustment:**

Yes

**24. Vacuum time adjustment:**

Yes

**25. Lid security element:**

Yes

**26. Manometer:**

Yes

**27. Width of internal part [mm]:**

435

**28. Depth of internal part [mm]:**

455

# Technical data sheet

Technical parameters



Vacuum packing machine 20 m<sup>3</sup>/h, 410 mm

**Model**

**SAP Code**

00013548

## 29. Height of internal part [mm]:

175